



**MILCOM a. s.**

Hradecká 1456  
544 01 Dvůr Králové n. L.  
Czech Republic  
Tel.: +420 499 320 280  
Fax: +420 499 320 364  
E-mail: milcomdk@milcom-as.cz  
www.milcom-as.cz



ISO 9001 certified company

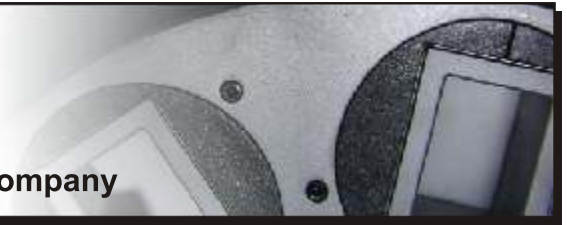

## Butter Transport and Buffer unit DMC-2

The butter conveying device is recommended to be used for sanitary reasons - to prevent butter from contact with surrounding environment on its way between the buttermaking machine and packing machine.

The Butter Conveying Device DMC-2 includes following parts:

- silo volume 500, 1000 or 1500 l with screws
- butter pump with engine
- control panel
- set of spare parts

### Parameters:

<b>Output</b>	up to 3000 kg/hour
<b>Max. transport height</b>	0,45 MPa
<b>Capacity of the silo</b>	500 - 1500 liters
<b>Power consumption</b>	2 kW/1000 kg of transported butter
<b>Weight of the machine</b>	approx. 1.100 kg
<b>Working life</b>	15 - 20 years

- The Butter Conveying Device DMC-2 is installed at the outlet from the buttermaking machine where longer distance to the packing machine is required.
- The device consists of the buffer tank with feed screws and butter pump.



- The device is suitable for butter line with capacity from 1000 up to 3000 kg/hour.
- All parts coming into contact with butter are made of stainless steel.

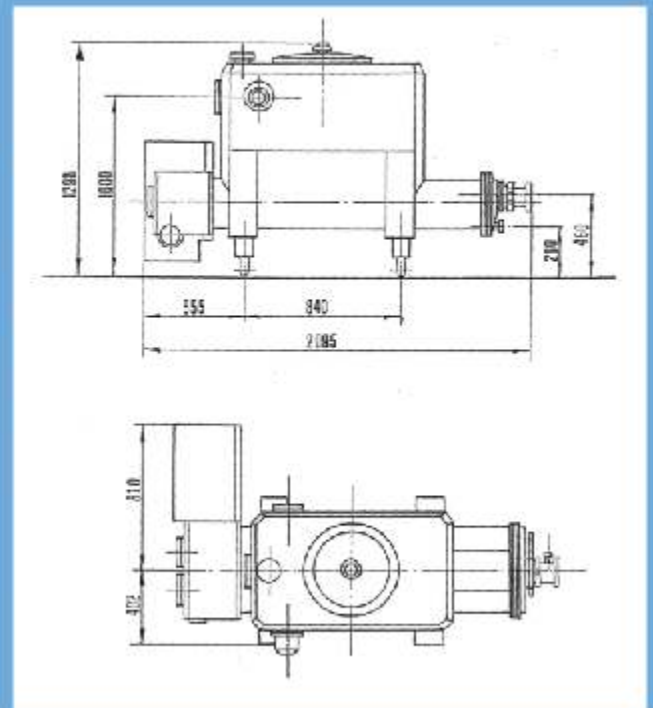

**MILCOM a. s.**

Hradecká 1456, CZ-54401 Dvůr Králové n. L., Czech Republic, Tel.: +420 499 320 280  
Fax: +420 499 320 364, E-mail: milcomdk@milcom-as.cz, www.milcom-as.cz